

**HEATER600-SMART-400V** [↗](#)

Induction heating device

Schaeffler ID:
0966769730000

HEATER smart

Technical information

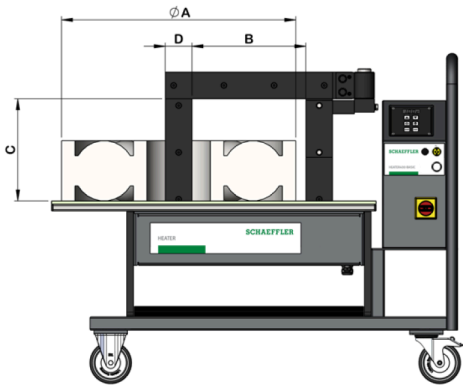
**Technical data**

U	400 V	Operating voltage
f	50 – 60 Hz	Power frequency
P	18 kVA	Power consumption
I	45 A	Current rating
$\vartheta_{h \max}$	240 °C	Max. heating temperature
	0 – 99 min	Heating time
	Touch	Display
	2	Magnetic probe, quantity
≈m	210 kg	Weight

Functions

+	Temperature hold
+	Automatic demagnetization, <2A/cm
+	Swivel arm
+	Log function
+	Delta-T control
+	Temperature control
+	Time control
+	Temperature and time control
+	Temperature and speed control
+	Overheating protection
only in temp. and speed mode	Automatic power reduction
+	Device supports horizontal / lying heating of the workpiece
+	Device supports vertical / hanging heating of the workpiece
+	Device mobile

**Dimensions**

	1,344 mm	Length HEATER
	560 mm	Width HEATER
	990 mm	Height HEATER
B	400 mm	Space between poles
C	315 mm	Pole length
D	90x110	Pole cross section (mm ²)

Workpiece to be heated

	130 mm	Min. inner diameter workpiece, vertical heating: with included yoke
	60 mm	Min. inner diameter workpiece, vertical heating: with optional yoke
	150 mm	Min. inner diameter workpiece, horizontal heating
ØA _{max}	1,050 mm	Max. outer diameter workpiece
	395 mm	Max. workpiece width, vertical heating
	310 mm	Max. workpiece width, horizontal heating
m _{b max}	600 kg	Max. workpiece weight

Additional information

	1	Yokes included, quantity
	90x90	Yokes included, cross section (mm ²)